



FAQs

1. How long does Savasocket take to programme? About 30 seconds and then you can connect all the required items.

2. Do I need a special remote control to use Savasocket? No, you can use any home infra red remote to programme Savasocket.

3. I am having problems getting the Savasocket to learn my remote control button. When programming the Savasocket make sure you are away from bright lights and direct sunlight as they can emit infra red signals that may confuse the programming. If you are still having problems, try changing the batteries in your remote control unit.

4. How far away can I be from the Savasocket and still use my remote control? This depends on the model and how good the batteries are, but generally up to 10m would be ok.

5. Can I add an extension lead to one of the four sockets controlled by my remote? Yes, you can add an extension lead to give you more sockets.

6. Can I connect my audio system to Savasocket? Yes, you can save money by also turning off an audio system.

7. Can Savasocket be used to connect my children's games console? Yes, the more items you connect that can be left on standby, the more money you will save.

8. Does a Savasocket use much energy in standby? No, unlike some other products in the market, Savasocket saves far more energy than it uses. The Energy Saving Trust's standard is 1 watt; Savasocket only uses 0.19 of a watt.

9. What is Standby? Most TVs, videos, DVD/Blue ray, Freeview boxes and Audio systems have standby. It is the power used by electronic devices that are turned on, but not running.

10. When I turn off my connected appliances, does Savasocket perform a soft shut down to save wear and tear? Yes, Savasocket has a soft shut down feature built-in to extend the life of all connected items.

11. I've heard that leaving electrical appliances such as TVs, CD players, monitors etc on standby uses very little energy and means the warm up time is reduced - is this true? No, in general appliances such as TVs and CD players use more electricity in standby mode than their owners realise. A TVs standby generally uses 3-7W, compared with around 140W when switched on, but over the course of the year, this can really add up. The average house can save £37* a year by turning things off rather than leaving them on standby. Most modern appliances do not need a warm up time. One exception to this is 'complex' digital set-top boxes, which need to be left in standby to keep their settings. Nearly all other appliances can be turned off fully with no problems.

*Source: Energy Saving Trust

Warranty

Savasocket products are warranted against defects in materials and workmanship for a period of one year. Where the product is sold under a consumer transaction (as defined by the Sale of Goods Act 1979) the statutory rights of the purchaser are not affected by this warranty. Please register your Savasocket online at www.savasocket.com/support. When registering warranty please have the serial number which is located on the back of the unit.

for more information visit www.savasocket.com



To help the environment, we recommend that discarded electrical equipment is disposed of at a WEEE (Waste Electrical & Electronic Equipment) collection site.



energy saving device
user instructions





Saves Money Saves Energy

Switches off TVs and connected appliances at the touch of a button

Savasocket has 4 plug points that are controlled by your own remote control and 2 that are permanently connected to the mains. The infra red eye is supplied so that you can place the Savasocket behind your TV, DVD player etc and still control it via your remote control.

for more information
visit www.savasocket.com

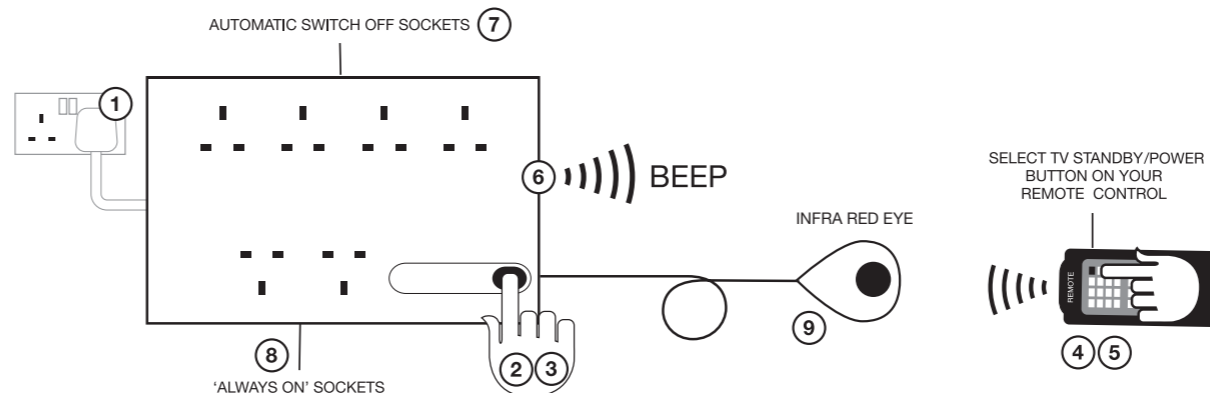

It is essential before programming your Savasocket that you ensure you are away from both bright lights and direct sunlight. They can emit infra red signals which could interfere with the programming.

- ① Plug the Savasocket into any mains supply and an amber light appears on the Savasocket button to indicate the power is on.
- ② Press the amber button on the front of the Savasocket once and the light glows Green to indicate Savasocket is active.

- ③ Press and hold this button for 5 seconds and the Savasocket will beep. At the same time a red light will appear, indicating Savasocket is now in learning mode and ready to receive a signal from your remote control.
NOTE: It is essential before programming your Savasocket that you ensure you are away from both bright lights and direct sunlight.
- ④ We suggest you use the TV standby button on your remote control to program the Savasocket.

- ⑤ Now point the remote control at the infra red eye. Press and hold the standby button until you hear a confirmation beep and repeat this process 9 times.
- ⑥ When you have completed the above, the light on the Savasocket will change from red to amber and the Savasocket will beep three times to confirm it has been programmed.
- ⑦ You can now plug into your Savasocket any of the items you want to turn on and off with your remote control, such as your TV,

DVD player etc.
The items plugged into the bank of four sockets will now be controlled by your remote control. It is therefore important to carefully choose which appliances are plugged into the four socket side.

- ⑧ You can plug your Sky+ / Sky HD / Freeview / Video Recorder into one of the 'ALWAYS ON' sockets. These sockets should be used only for appliances you require to be 'always on'

- ⑨ Now put the Savasocket behind your TV etc, and place the infra red eye in front so that when you point your remote control at the infra red eye it can receive the signal. You can now switch on and off the Savasocket using your infra red remote.
- From now on, your television and anything plugged into the bank of 4 sockets will automatically power down when you press the standby button you have chosen.
- If you change your remote control unit, simply repeat



the above procedure to re-programme the Savasocket. Don't worry about going away on holiday. Savasocket will remember your programmed button.

If you're having any difficulties with this product please contact our service helpline on UK: **0871 702 9007**, International call **0044871 702 9007**. Calls to this number from the UK are charged at 10p per minute from a BT landline. Other operators and mobiles may vary. Charge based on the BT rate at October 2010.